

Name: _____

Date: _____

Unit 11 Review Packet

Test Topics

- Partitioning a Line Segment
- Sum of the Interior Angles of a Polygon
- Area of 2D shapes
 - Triangle, circle, parallelograms, trapezoids
 - Shaded regions
- Volume of 3D shapes
 - Prisms, Pyramids, Cones, Cylinders, Spheres
 - Finding missing dimensions
 - Compound figures
- Density
- Unit Conversions (applied problems)
- Cross Sections
- Cavalieri's Principle
- Generatrix
- Surface Area
 - Rectangular Prism and Cylinder

Partitioning a Line Segment

Find the point P that partitions the segment with the two given endpoints AB into the given ratio.

1. $A(8, -5)$ $B(4, 7)$ 1:3

2. $A(2, 4)$ $B(8, 10)$ 5:1

Sum of the Interior Angles of Polygon

Find the interior angle sum for each polygon.

1. Regular 20-gon

2. Regular 13-gon

3. Find the measure of one interior angle in a 30-gon

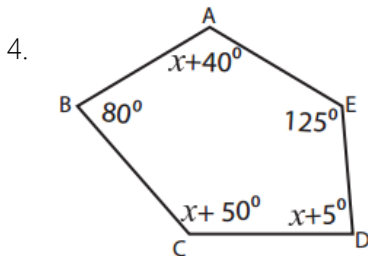

Sum of the interior angles = _____

$x =$ _____ ; $\angle A =$ _____ ; $\angle C =$ _____ ; $\angle D =$ _____

Area of 2D Shapes

Find the area of each of the 2D shapes

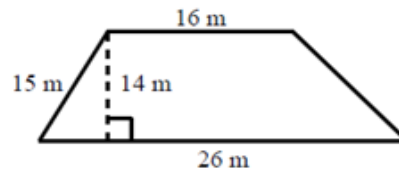
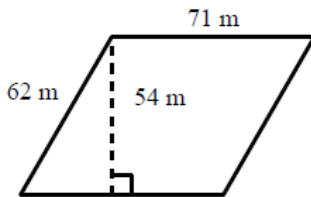

Find the area of the shaded region to the nearest tenth.

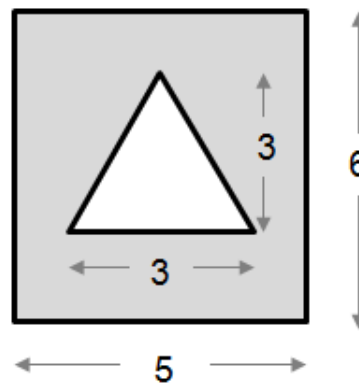
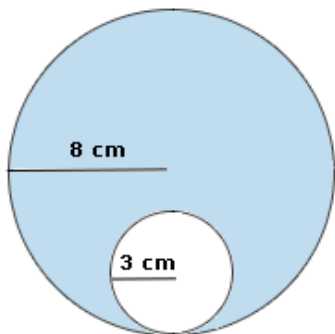

Volume of 3D Figures

Find the volume of each shape in terms of pi where necessary

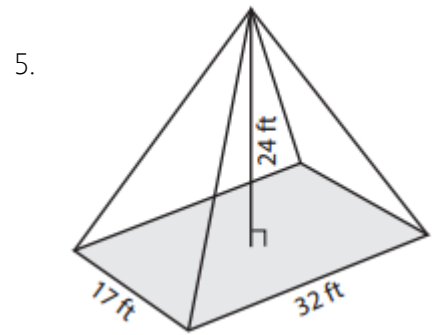
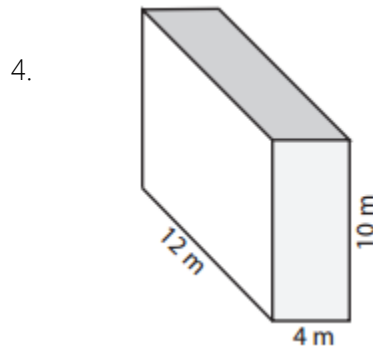
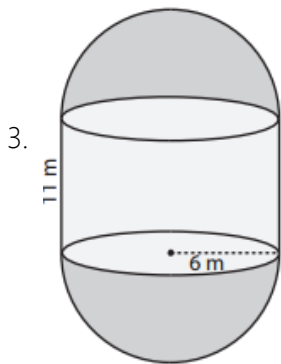
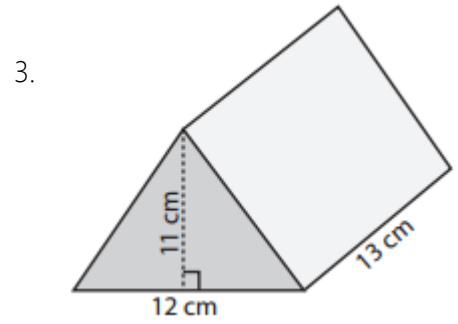
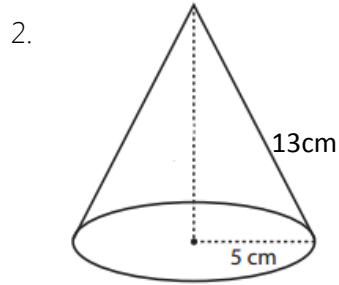
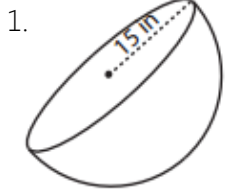

6. The volume of a cylinder is 468π cubic inches. If the cylinder's height is 13 inches, what is its radius?

7. If the area of the shaded region of the sphere below is 16π in², what is the volume of the sphere in terms of pi?

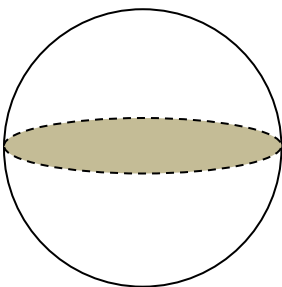

Density and Unit Conversions

1. The approximate dimensions of an Olympic-size swimming pool are 164ft by 82ft by 6.6 ft. If $1\text{ft}^3 = 7.48\text{gal}$, about how many gallons does the pool hold?

2. The density of the American white oak tree is 752 kilograms per cubic meter. If the trunk of an American white oak tree has a radius of 4.5 meters and the height of the trunk is 8 meters, what is the mass in kilograms of the trunk to the nearest whole kilogram?

3. Trees that are cut down and stripped of their branches for timber are approximately cylindrical. A timber company specializes in a certain type of tree that has a typical diameter of 50 cm and a typical height of about 10 meters. The density of the wood is 380 kilograms per cubic meter, and the wood can be sold by mass at a rate of \$4.75 per kilogram. How much can one tree be sold for?

Cross Sections of 3D Figures

Draw the shape resulting from each cross section:

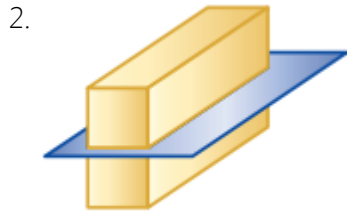
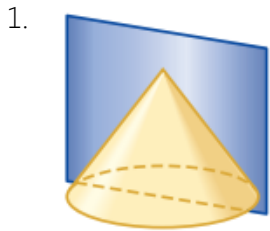

4. The figure below is a square pyramid. Which is not a possible cross section?

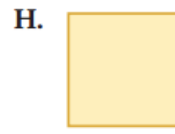

Cavalieri's Principle

1. Looking at the stack of quarters below, what do we know about their volumes? Explain why.

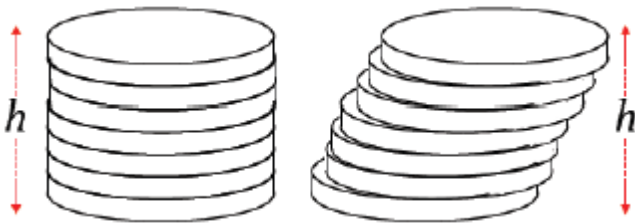

2. A triangular prism has a base length of 20, base height of 4 and a prism height of 15. A square prism has a height of 15 and its volume is equal to that of the rectangular prism. What are the dimensions of the square base, in simplest radical form?

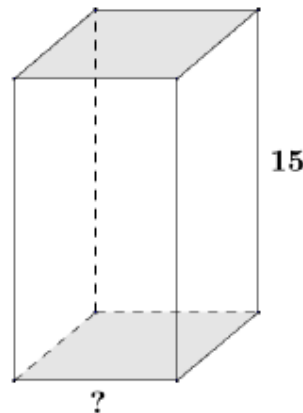
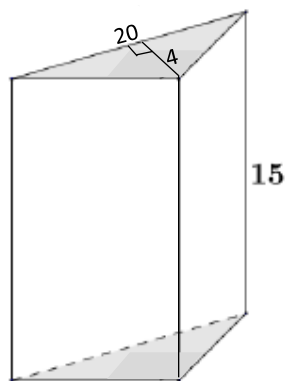

Generatrix

What shape is created when you rotate each of the figures around the given axis? Name the dimensions of the new shape (as if you were to find its volume)

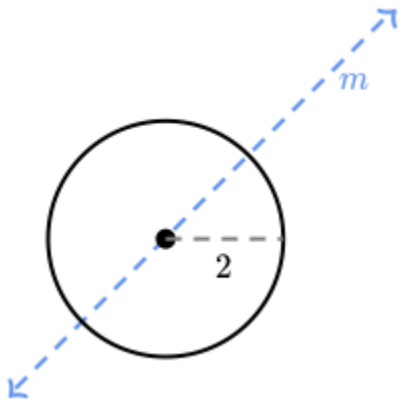

Shape: _____
Dimensions: _____

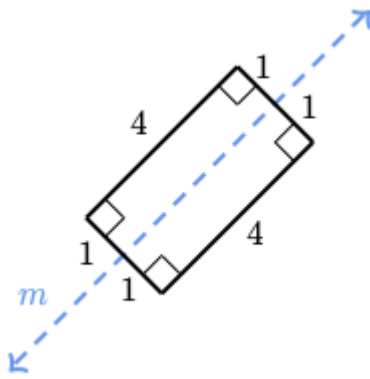

Shape: _____
Dimensions: _____

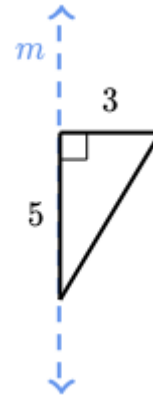

Shape: _____
Dimensions: _____

Surface Area

Find the surface area of each of the figures below to the nearest tenth.

